

RELIABILITY REPORT
FOR
MAX3223ExxP
PLASTIC ENCAPSULATED DEVICES

September 12, 2001

MAXIM INTEGRATED PRODUCTS

120 SAN GABRIEL DR.

SUNNYVALE, CA 94086

Written by



Jim Pedicord
Quality Assurance
Reliability Lab Manager

Reviewed by



Bryan J. Preeshl
Quality Assurance
Executive Director

Conclusion

The MAX3223E successfully meets the quality and reliability standards required of all Maxim products. In addition, Maxim's continuous reliability monitoring program ensures that all outgoing product will continue to meet Maxim's quality and reliability standards.

Table of Contents

I.Device Description	V.Quality Assurance Information
II.Manufacturing Information	VI.Reliability Evaluation
III.Packaging Information	IV.Die Information
Attachments

I. Device Description

A. General

The MAX3223E is a 3V-powered EIA/TIA-232 and V.28/V.24 communications interface with automatic shutdown/wakeup features, high data rate capabilities, and enhanced electrostatic discharge (ESD) protection. All transmitter outputs and receiver inputs are protected to $\pm 15\text{kV}$ using IEC 1000-4-2 Air-Gap Discharge, to $\pm 8\text{kV}$ using IEC 1000-4-2 Contact Discharge, and to $\pm 15\text{kV}$ using the Human Body Model.

The MAX3223E achieves a $1\mu\text{A}$ supply current with Maxim's revolutionary AutoShutdown™ feature. It saves power without changes to the existing BIOS or operating system by entering low-power shutdown mode when the RS-232 cable is disconnected, or when the transmitters of the connected peripherals are off.

This transceiver has a proprietary low-dropout transmitter output stage, delivering true RS-232 performance from a +3.0V to +5.5V supply with a dual charge pump. The charge pump requires only four small $0.1\mu\text{F}$ capacitors for operation from a +3.3V supply. The MAX3223E is guaranteed to run at data rates of 250kbps while maintaining RS-232 output levels. The MAX3223E contains two drivers and two receivers

B. Absolute Maximum Ratings

<u>Item</u>	<u>Rating</u>
V_{CC} to GND	-0.3V to +6V
V+ to GND (Note 1)	-0.3V to +7V
V- to GND (Note 1)	+0.3V to -7V
V+ + V- (Note 1)	+13V
Input Voltages	
T_IN, /EN, FORCEON, /FORCEOFF to GND	-0.3V to +6V
R_IN to GND	$\pm 25\text{V}$
Output Voltages	
T_OUT to GND	$\pm 13.2\text{V}$
R_OUT, R2OUTB, /INVALID to GND	-0.3V to ($V_{CC} + 0.3\text{V}$)
Short-Circuit Duration	
T_OUT to GND	Continuous
Storage Temp.	-65°C to +160°C
Lead Temp. (10 sec.)	+300°C
Power Dissipation	
20-Pin DIP	889mW
20-Pin SSOP	640mW
20-Pin TSSOP	559mW
Derates above +70°C	
20-Pin DIP	11.11mW/°C
20-Pin SSOP	8.0mW/°C
20-Pin TSSOP	7.1mW/°C

Note 1: V+ and V- can have maximum magnitudes of 7V, but their absolute difference cannot exceed 13V.

II. Manufacturing Information

- A. Description/Function: $\pm 15\text{kV}$ ESD-Protected, $1\mu\text{A}$, 3.0V to 5.5V, 250kbps, RS-232 Transceiver with AutoShutdown
- B. Process: SG3 (Standard 3 micron silicon gate CMOS)
- C. Number of Device Transistors: 339
- D. Fabrication Location: California or Oregon, USA
- E. Assembly Location: Philippines or Malaysia
- F. Date of Initial Production: January, 1998

III. Packaging Information

A. Package Type:	20-Pin PDIP	20-Pin SSOP	20-Pin TSSOP
B. Lead Frame:	Copper	Copper	Copper
C. Lead Finish:	Solder Plate	Solder Plate	Solder Plate
D. Die Attach:	Silver-filled Epoxy	Silver-filled Epoxy	Silver-filled Epoxy
E. Bondwire:	Gold (1.3 mil dia.)	Gold (1.3 mil dia.)	Gold (1.3 mil dia.)
F. Mold Material:	Epoxy with silica filler	Epoxy with silica filler	Epoxy with silica filler
G. Assembly Diagram:	# 05-1901-0182	# 05-1901-0189	# 05-1901-0202
H. Flammability Rating:	Class UL94-V0		

IV. Die Information

- A. Dimensions: 91 x 159 mils
- B. Passivation: $\text{Si}_3\text{N}_4/\text{SiO}_2$ (Silicon nitride/ Silicon dioxide)
- C. Interconnect: Aluminum/Si (Si = 1%)
- D. Backside Metallization: None
- E. Minimum Metal Width: 3 microns (as drawn)
- F. Minimum Metal Spacing: 3 microns (as drawn)
- G. Bondpad Dimensions: 5 mil. Sq.
- H. Isolation Dielectric: SiO_2
- I. Die Separation Method: Wafer Saw

V. Quality Assurance Information

- A. Quality Assurance Contacts: Jim Pedicord (Reliability Lab Manager)
Bryan Preeshl (Executive Director)
Kenneth Huening (Vice President)
- B. Outgoing Inspection Level: 0.1% for all electrical parameters guaranteed by the Datasheet.
0.1% For all Visual Defects.
- C. Observed Outgoing Defect Rate: < 50 ppm
- D. Sampling Plan: Mil-Std-105D

VI. Reliability Evaluation

A. Accelerated Life Test

The results of the 135°C biased (static) life test are shown in **Table 1**. Using these results, the Failure Rate (λ) is calculated as follows:

$$\lambda = \frac{1}{\text{MTTF}} = \frac{8.35}{192 \times 4389 \times 360 \times 2} \quad (\text{Chi square value for MTTF upper limit})$$

↓
Temperature Acceleration factor assuming an activation energy of 0.8eV

$$\lambda = 13.76 \times 10^{-9}$$

$$\lambda = 13.76 \text{ F.I.T. (60\% confidence level @ 25°C)}$$

This low failure rate represents data collected from Maxim's reliability monitor program. In addition to routine production Burn-In, Maxim pulls a sample from every fabrication process three times per week and subjects it to an extended Burn-In prior to shipment to ensure its reliability. The reliability control level for each lot to be shipped as standard product is 59 F.I.T. at a 60% confidence level, which equates to 3 failures in an 80 piece sample. Maxim performs failure analysis on any lot that exceeds this reliability control level. Attached Burn-In Schematic (Spec. # 06-5072) shows the static Burn-In circuit. Maxim also performs quarterly 1000 hour life test monitors. This data is published in the Product Reliability Report (**RR-1L**).

B. Moisture Resistance Tests

Maxim pulls pressure pot samples from every assembly process three times per week. Each lot sample must meet an LTPD = 20 or less before shipment as standard product. Additionally, the industry standard 85°C/85%RH testing is done per generic device/package family once a quarter.

C. E.S.D. and Latch-Up Testing

The RS60-1 die type has been found to have all pins able to withstand a transient pulse of $\pm 3000\text{V}$, per Mil-Std-883 Method 3015 (reference attached ESD Test Circuit). Additionally, the MAX3223E has achieved $\pm 15\text{kV}$ ESD protection using both methods 3015 and IEC 801-2 (air-gap discharge) on the I/O pins. Latch-Up testing has shown that this device withstands a current of $\pm 250\text{mA}$ and/or $\pm 20\text{V}$.

Table 1
Reliability Evaluation Test Results

MAX3223ExxP

TEST ITEM	TEST CONDITION	FAILURE IDENTIFICATION	PACKAGE	SAMPLE SIZE	NUMBER OF FAILURES
Static Life Test (Note 1)					
	Ta = 135°C Biased Time = 192 hrs.	DC Parameters & functionality		360	0
Moisture Testing (Note 2)					
Pressure Pot	Ta = 121°C P = 15 psi. RH= 100% Time = 168hrs.	DC Parameters & functionality (generic test vehicle)	PDIP	80	0
			SSOP	300	1
			TSSOP	77	0
85/85	Ta = 85°C RH = 85% Biased Time = 1000hrs.	DC Parameters & functionality (generic test vehicle)		77	0
Mechanical Stress (Note 2)					
Temperature Cycle	-65°C/150°C 1000 Cycles Method 1010	DC Parameters (generic test vehicle)		77	0

Note 1: Life Test Data may represent plastic D.I.P. qualification lots.

Note 2: Generic Package/Process data

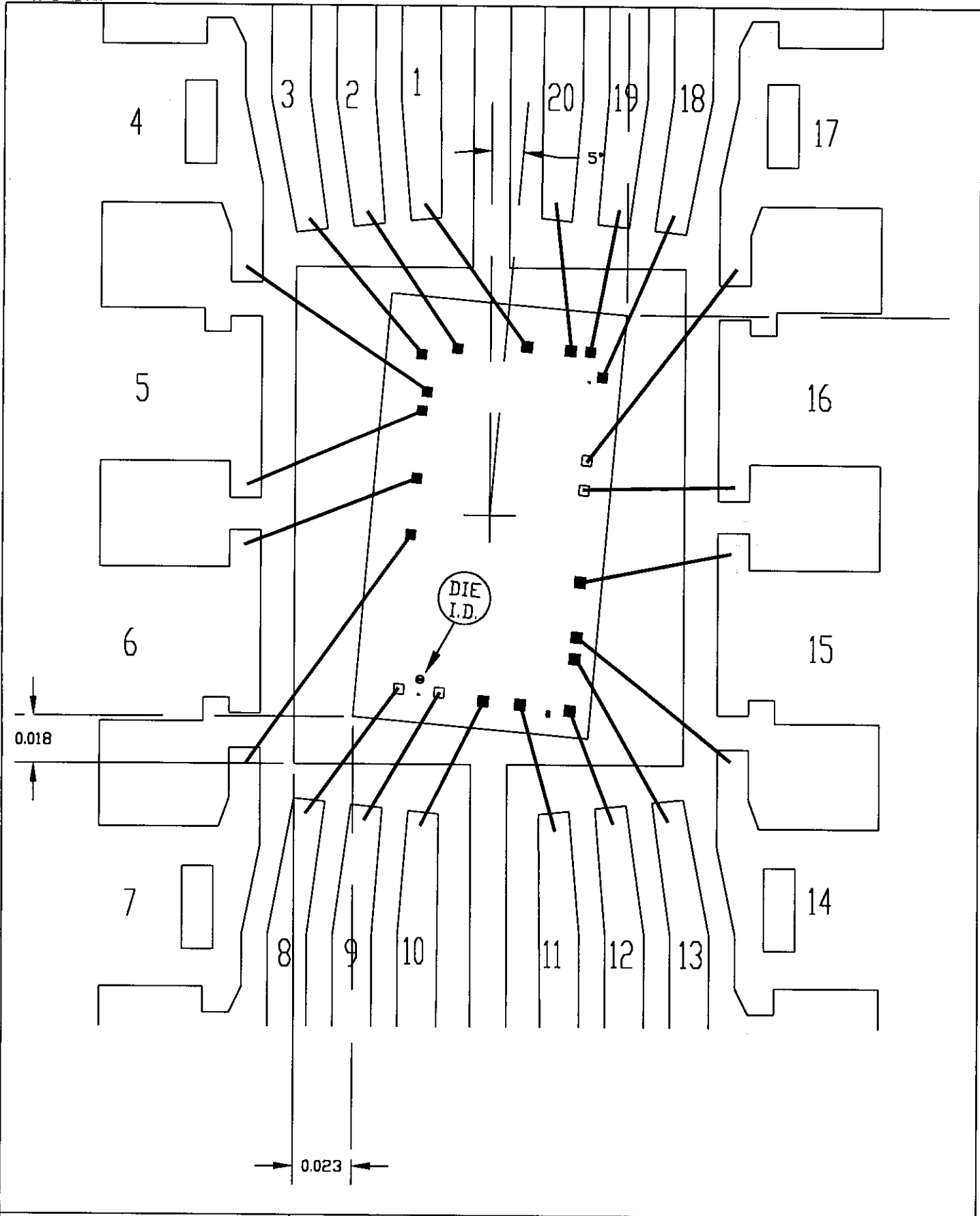

PKG.CODE: P20-3		APPROVALS	DATE	 BUILDSHEET NUMBER: 05-1901-0182 REV: B	
CAV./PAD SIZE: 150 X 190	PKG. DESIGN				

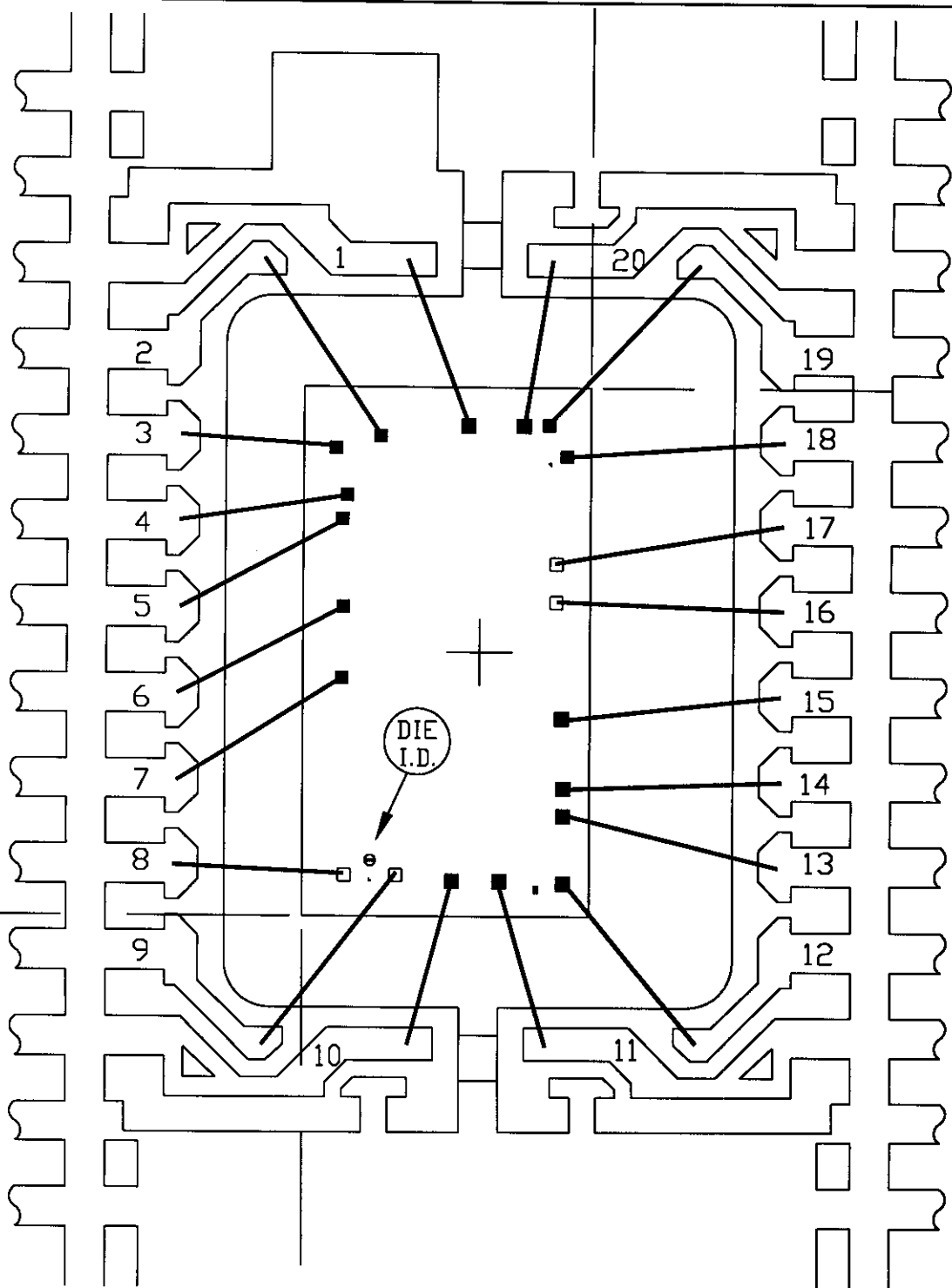

PKG.CODE: A20-2

CAV./PAD SIZE:
154X213

APPROVALS

DATE

MAXIM

BUILDSHEET NUMBER:
05-1901-0189

REV:
A

PKG.
DESIGN

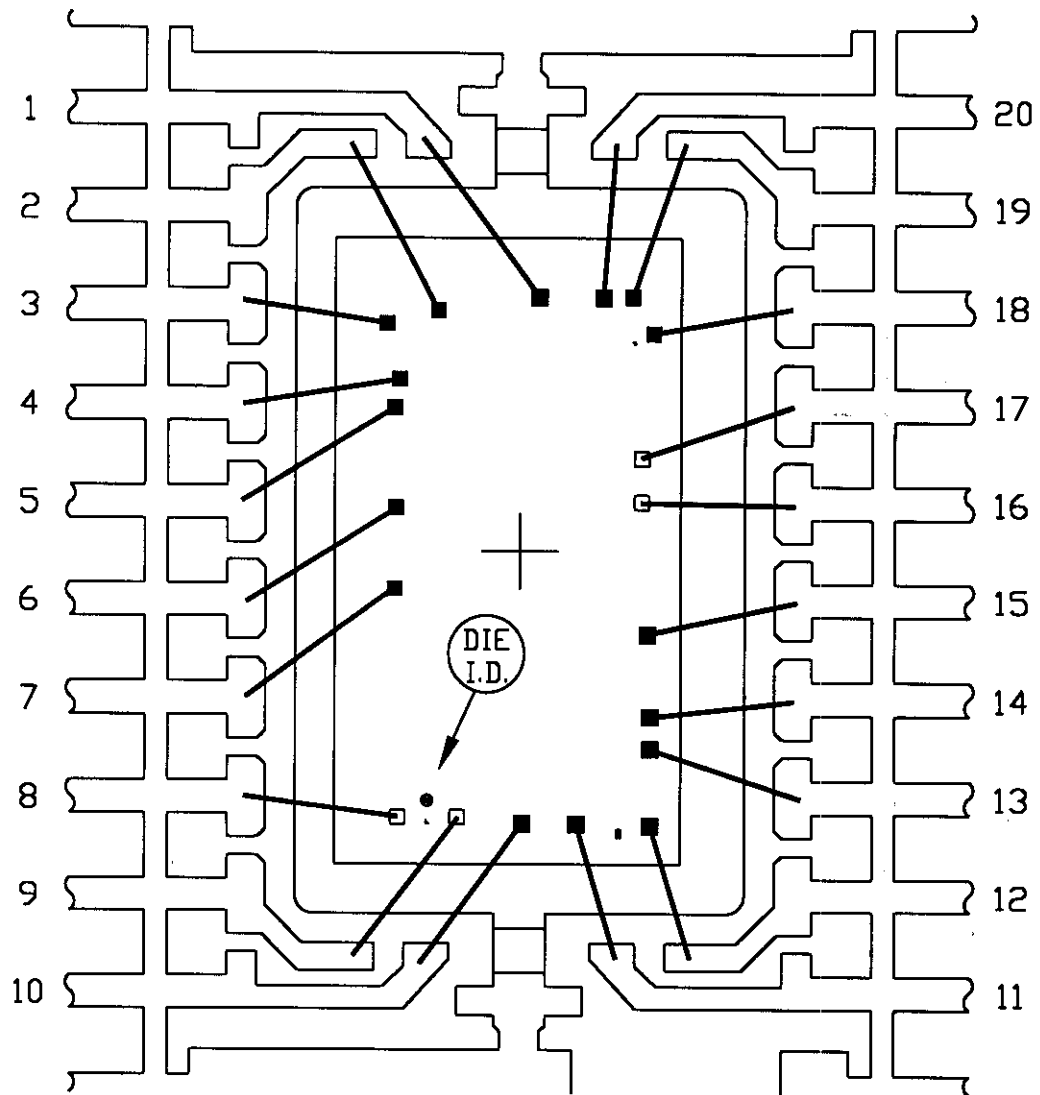

PKG.CODE: U20-2

CAV./PAD SIZE:
118X189

APPROVALS

DATE

MAXIM

BUILDSHEET NUMBER:
05-1901-0202

REV.:
A

PKG.
DESIGN

ONCE PER SOCKET

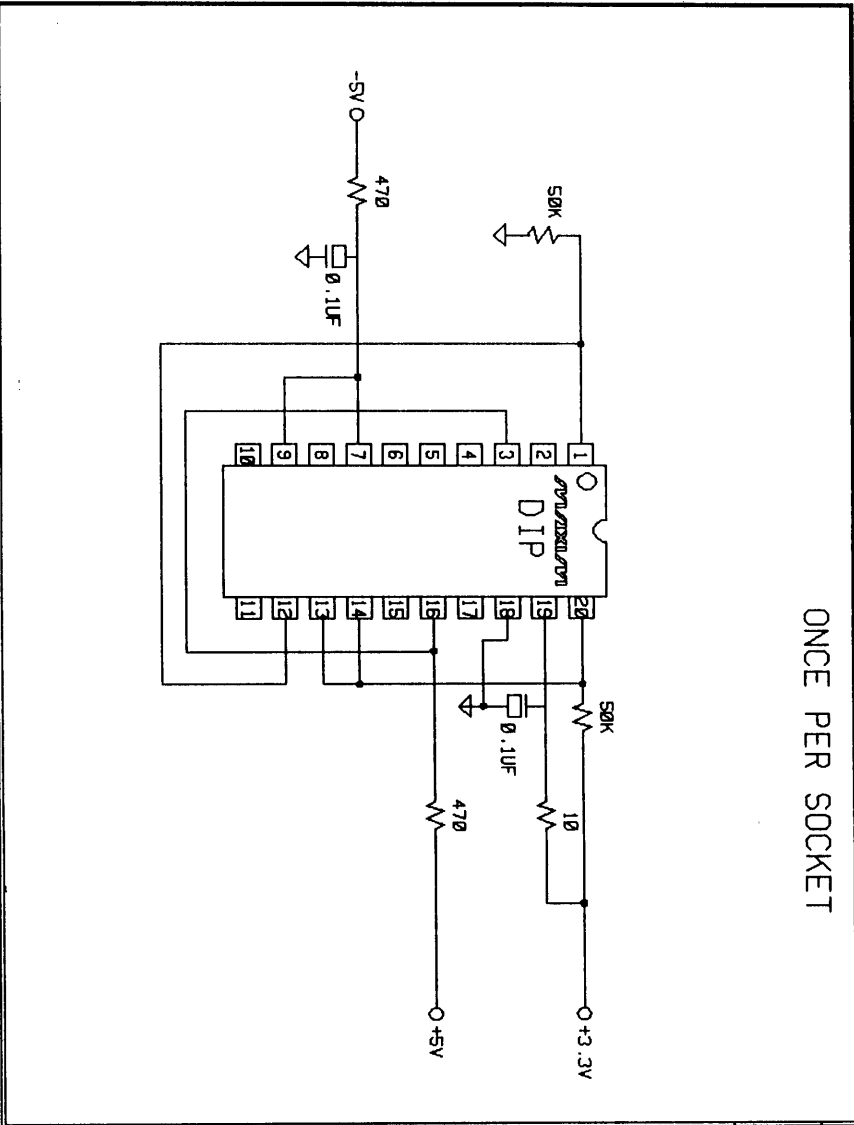

ONCE PER BOARD

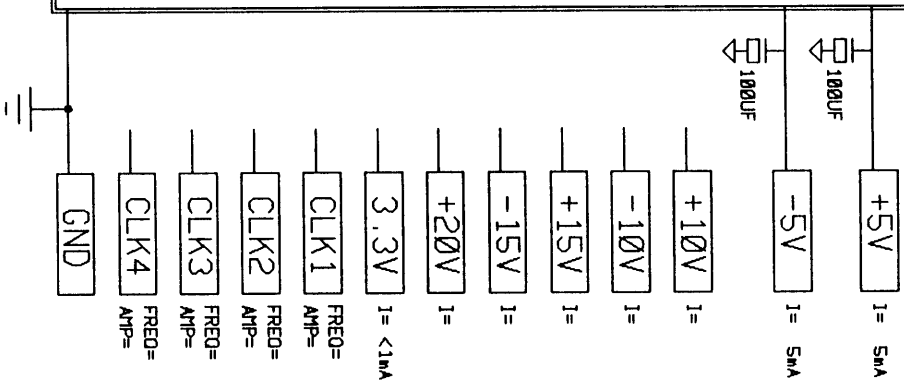

-STEADY STATE LIFE TEST IS PER MIL-STD-883 METHOD 1005.
-BURN-IN IS PER MIL-STD-883 METHOD 1015. COND. B

NOTES:

1. TEMPERATURE: 125C OR EQUIVALENT
2. TIME: 168 HOURS MIN. OR EQUIVALENT
3. ALL COMPONENTS AND MATERIAL MUST STAND 150C CONTINUOUS
4. APPROVED FOR: [X] COMMERCIAL, [X] HR/883
5. ALL RESISTORS: 1/4W MF, UOS

SPEC. NO. 06-5072 REV. A

DATE: 8/1/94

DRAWN BY:

MAXIM BURN-IN SCHEMATIC

DEVICE TYPE:

MAX3223