

RELIABILITY REPORT  
FOR  
**MAX6460UT**  
PLASTIC ENCAPSULATED DEVICES

April 3, 2004

**MAXIM INTEGRATED PRODUCTS**

120 SAN GABRIEL DR.

SUNNYVALE, CA 94086

Written by



Jim Pedicord  
Quality Assurance  
Reliability Lab Manager

Reviewed by



Bryan J. Preeshl  
Quality Assurance  
Executive Director

## Conclusion

The MAX6460 successfully meets the quality and reliability standards required of all Maxim products. In addition, Maxim's continuous reliability monitoring program ensures that all outgoing product will continue to meet Maxim's quality and reliability standards.

## Table of Contents

I. ....Device Description	V. ....Quality Assurance Information
II. ....Manufacturing Information	VI. ....Reliability Evaluation
III. ....Packaging Information	IV. ....Die Information
	.....Attachments

### I. Device Description

#### A. General

The MAX6460 high supply voltage, low-power voltage monitor operates over a 4V to 28V supply voltage range. The device includes a precision bandgap reference, one or two low-offset-voltage comparators, internal threshold hysteresis, power-good or reset timeout options, and one or two high-voltage open-drain outputs. Two external resistors (three for window detection) set the trip threshold voltages.

The MAX6460 is a single-voltage monitor for undervoltage or overvoltage detection. A logic-based clear input either latches the output for overvoltage applications or allows the device to operate in transparent mod.

The MAX6460 includes a single comparator and an internal reference, and can also accept an external reference. The inverting and noninverting inputs of the comparator are externally accessible to support positive or negative voltage monitors and to configure the device for active-high or active-low output logic.

The MAX6460 offers a fixed 50 $\mu$ s timeout period. Internal threshold hysteresis of 0.5% reduces output chatter in noise-sensitive applications. The device is available in a small SOT23 package and is specified over the extended temperature range of -40°C to +125°C.

#### B. Absolute Maximum Ratings

<u>Item</u>	<u>Rating</u>
VCC, OUT, OUTA, OUTB, CLEAR to GND	-0.3V to +30.0V
IN+, IN- to GND	-0.3V to (VCC + 0.3V)
REF to GND	-0.3V to the lower of +6V and (VCC + 0.3V)
Input Currents (VCC, IN+, IN-)	20mA
Sink Current (OUT, OUTA, OUTB)	20mA
Junction Temperature	+150°C
Operating Temperature Range	-40°C to +125°C
Storage Temperature Range	-65°C to +150°C
Lead Temperature (soldering, 10s)	+300°C
Continuous Power Dissipation (TA = +70°C)	
5-Pin SOT23	571mW
Derates above +70°C	
5-Pin SOT23	7.1mW/°C

## II. Manufacturing Information

A. Description/Function:	High-Voltage, Low-Current Voltage Monitors in SOT Package
B. Process:	S8 (Standard 0.8 micron silicon gate CMOS)
C. Number of Device Transistors:	785
D. Fabrication Location:	California, USA
E. Assembly Location:	Malaysia or Thailand
F. Date of Initial Production:	July, 2002

## III. Packaging Information

A. Package Type:	<b>5-Pin SOT23</b>
B. Lead Frame:	Copper
C. Lead Finish:	Solder Plate
D. Die Attach:	Silver-filled Epoxy
E. Bondwire:	Gold (1 mil dia.)
F. Mold Material:	Epoxy with silica filler
G. Assembly Diagram:	# 05-1601-0190
H. Flammability Rating:	Class UL94-V0
I. Classification of Moisture Sensitivity per JEDEC standard J-STD-020-A:	Level 1

## IV. Die Information

A. Dimensions:	53 x 35 mils
B. Passivation:	$\text{Si}_3\text{N}_4/\text{SiO}_2$ (Silicon nitride/ Silicon dioxide)
C. Interconnect:	Aluminum/Si (Si = 1%)
D. Backside Metallization:	None
E. Minimum Metal Width:	0.8 microns (as drawn)
F. Minimum Metal Spacing:	0.8 microns (as drawn)
G. Bondpad Dimensions:	5 mil. Sq.
H. Isolation Dielectric:	$\text{SiO}_2$
I. Die Separation Method:	Wafer Saw

## V. Quality Assurance Information

- A. Quality Assurance Contacts: Jim Pedicord (Manager, Reliability Operations)  
Bryan Preeshl (Executive Director)  
Kenneth Huening (Vice President)
- B. Outgoing Inspection Level: 0.1% for all electrical parameters guaranteed by the Datasheet.  
0.1% For all Visual Defects.
- C. Observed Outgoing Defect Rate: < 50 ppm
- D. Sampling Plan: Mil-Std-105D

## VI. Reliability Evaluation

### A. Accelerated Life Test

The results of the 135°C biased (static) life test are shown in **Table 1**. Using these results, the Failure Rate ( $\lambda$ ) is calculated as follows:

$$\lambda = \frac{1}{\text{MTTF}} = \frac{1.83}{192 \times 4389 \times 45 \times 2} \quad (\text{Chi square value for MTTF upper limit})$$

▲  
Temperature Acceleration factor assuming an activation energy of 0.8eV

$$\lambda = 24.13 \times 10^{-9}$$

$$\lambda = 24.13 \text{ F.I.T. (60\% confidence level @ 25°C)}$$

This low failure rate represents data collected from Maxim's reliability monitor program. In addition to routine production Burn-In, Maxim pulls a sample from every fabrication process three times per week and subjects it to an extended Burn-In prior to shipment to ensure its reliability. The reliability control level for each lot to be shipped as standard product is 59 F.I.T. at a 60% confidence level, which equates to 3 failures in an 80 piece sample. Maxim performs failure analysis on any lot that exceeds this reliability control level. Attached Burn-In Schematic (Spec. # 06-5976) shows the static Burn-In circuit. Maxim also performs quarterly 1000 hour life test monitors. This data is published in the Product Reliability Report (**RR-1M**).

### B. Moisture Resistance Tests

Maxim pulls pressure pot samples from every assembly process three times per week. Each lot sample must meet an LTPD = 20 or less before shipment as standard product. Additionally, the industry standard 85°C/85%RH testing is done per generic device/package family once a quarter.

### C. E.S.D. and Latch-Up Testing

The MS80-3 die type has been found to have all pins able to withstand a transient pulse of  $\pm 200\text{V}$  per Mil-Std-883 Method 3015 (reference attached ESD Test Circuit). Latch-Up testing has shown that this device withstands a current of  $\pm 250\text{mA}$ .

**Table 1**  
Reliability Evaluation Test Results

**MAX6460UT**

<b>TEST ITEM</b>	<b>TEST CONDITION</b>	<b>FAILURE IDENTIFICATION</b>	<b>PACKAGE</b>	<b>SAMPLE SIZE</b>	<b>NUMBER OF FAILURES</b>
<b>Static Life Test</b> (Note 1)					
	Ta = 135°C Biased Time = 192 hrs.	DC Parameters & functionality		45	0
<b>Moisture Testing</b> (Note 2)					
Pressure Pot	Ta = 121°C P = 15 psi. RH= 100% Time = 168hrs.	DC Parameters & functionality	SOT23	77	0
85/85	Ta = 85°C RH = 85% Biased Time = 1000hrs.	DC Parameters & functionality		77	0
<b>Mechanical Stress</b> (Note 2)					
Temperature Cycle	-65°C/150°C 1000 Cycles Method 1010	DC Parameters & functionality		77	0

Note 1: Life Test Data may represent plastic DIP qualification lots.

Note 2: Generic Package/Process data

Attachment #1

TABLE II. Pin combination to be tested. 1/ 2/

	Terminal A (Each pin individually connected to terminal A with the other floating)	Terminal B (The common combination of all like-named pins connected to terminal B)
1.	All pins except $V_{PS1}$ 3/	All $V_{PS1}$ pins
2.	All input and output pins	All other input-output pins

1/ Table II is restated in narrative form in 3.4 below.

2/ No connects are not to be tested.

3/ Repeat pin combination I for each named Power supply and for ground

(e.g., where  $V_{PS1}$  is  $V_{DD}$ ,  $V_{CC}$ ,  $V_{SS}$ ,  $V_{BB}$ , GND,  $+V_S$ ,  $-V_S$ ,  $V_{REF}$ , etc).

3.4 Pin combinations to be tested.

- a. Each pin individually connected to terminal A with respect to the device ground pin(s) connected to terminal B. All pins except the one being tested and the ground pin(s) shall be open.
- b. Each pin individually connected to terminal A with respect to each different set of a combination of all named power supply pins (e.g.,  $V_{SS1}$ , or  $V_{SS2}$  or  $V_{SS3}$  or  $V_{CC1}$ , or  $V_{CC2}$ ) connected to terminal B. All pins except the one being tested and the power supply pin or set of pins shall be open.
- c. Each input and each output individually connected to terminal A with respect to a combination of all the other input and output pins connected to terminal B. All pins except the input or output pin being tested and the combination of all the other input and output pins shall be open.

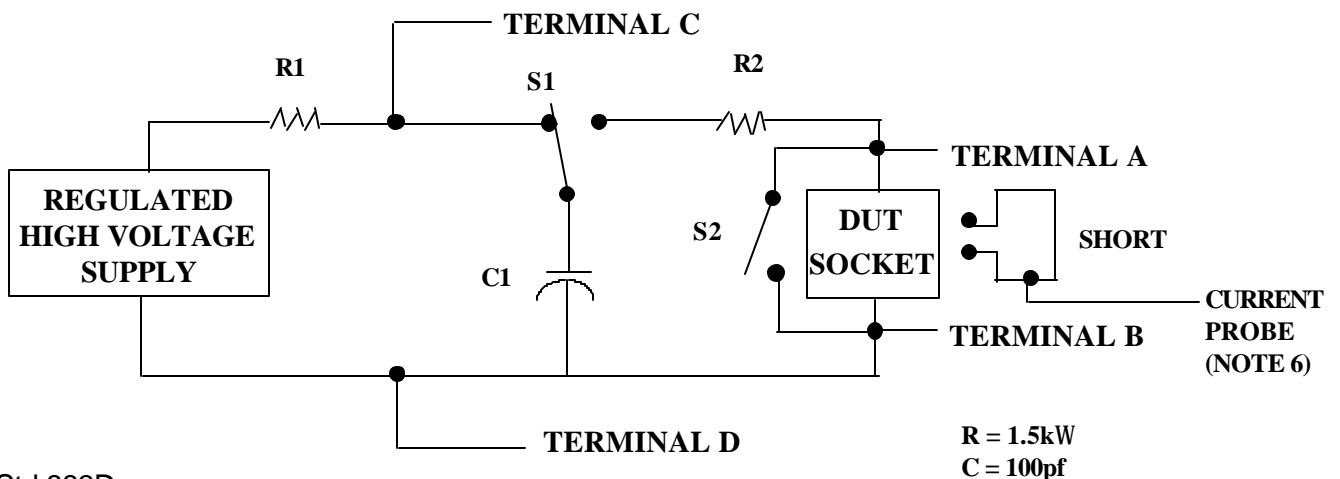

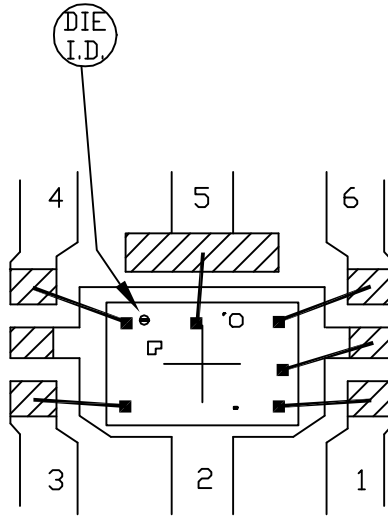

NOTE: CAVITY DOWN

PKG. CODE: U6-1		SIGNATURES	DATE	 CONFIDENTIAL & PROPRIETARY	
CAV./PAD SIZE: 64x39	PKG. DESIGN			BOND DIAGRAM #: 05-1601-0190	REV: A

ONCE PER SOCKET

ONCE PER BOARD

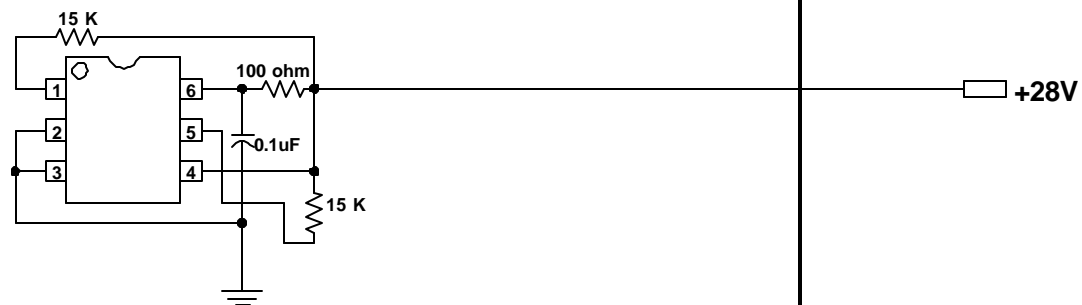

DEVICES: MAX 6459 MS80Z  
PACKAGE: 6-SOT  
MAX. EXPECTED CURRENT = 10uA